



# Professional

## GBH 18V-22

Robert Bosch Power Tools GmbH  
70538 Stuttgart  
GERMANY

[www.bosch-pt.com](http://www.bosch-pt.com)

1 609 92A 7C1 (2026.03) / 17



1 609 92A 7C1



en Original instructions





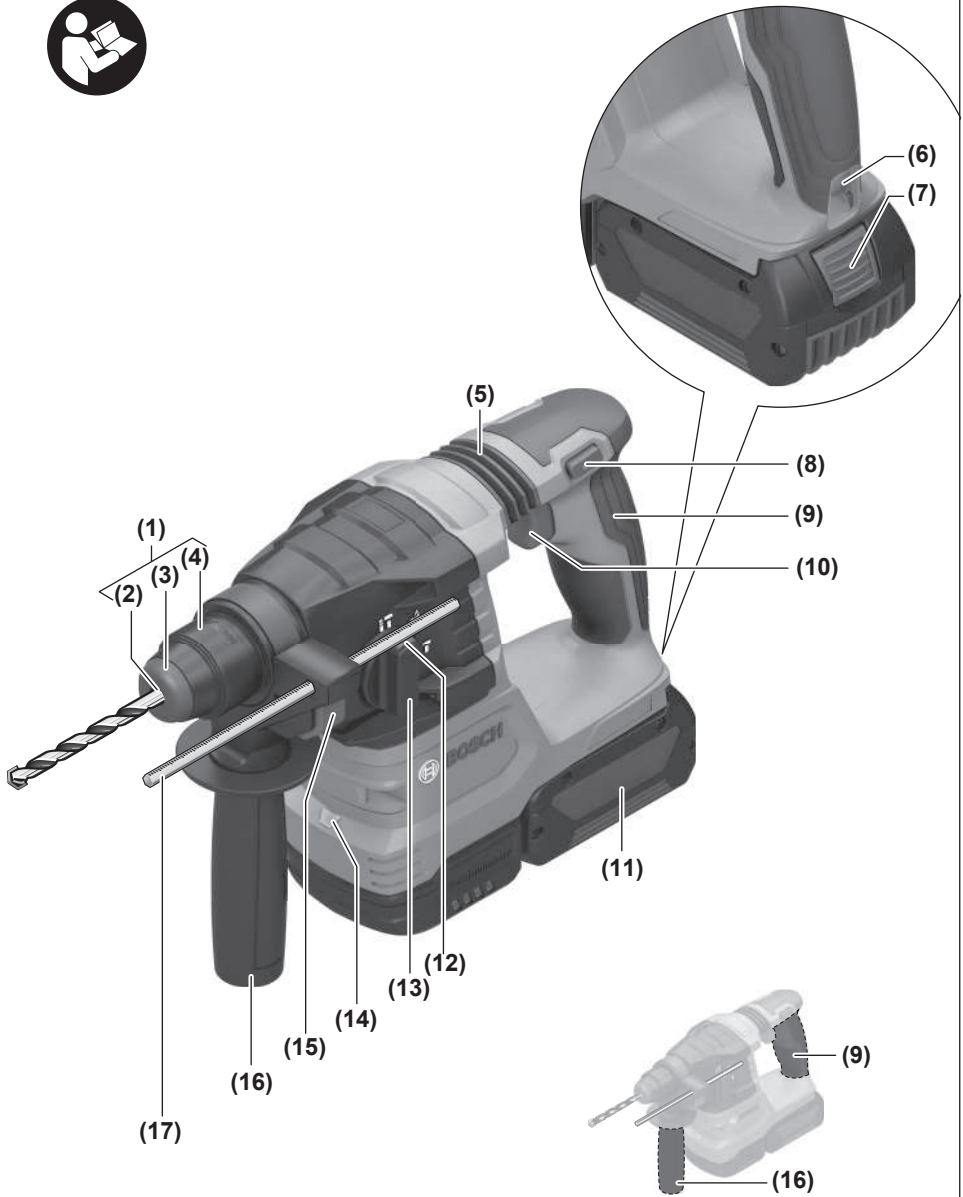

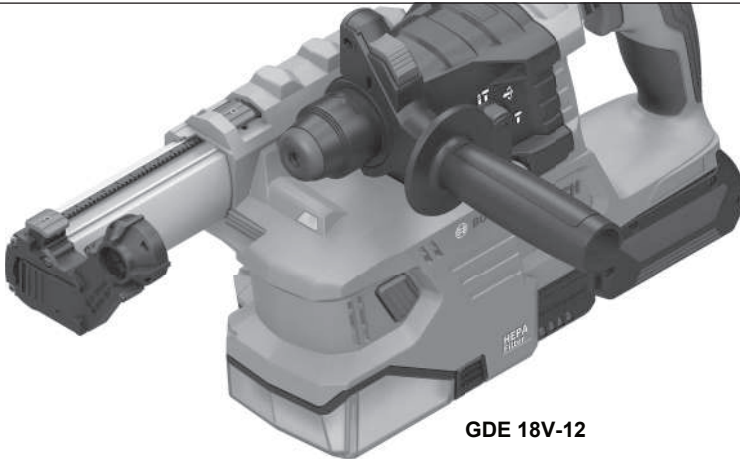

**G****GDE 18V-12****H****I****J**

# English

## Safety instructions

### General Power Tool Safety Warnings

**⚠ WARNING** Read all safety warnings, instructions, illustrations and specifications provided with this power tool. Failure to follow all instructions listed below may result in electric shock, fire and/or serious injury.

**Save all warnings and instructions for future reference.**

The term "power tool" in the warnings refers to your mains-operated (corded) power tool or battery-operated (cordless) power tool.

#### Work area safety

- ▶ **Keep work area clean and well lit.** Cluttered or dark areas invite accidents.
- ▶ **Do not operate power tools in explosive atmospheres, such as in the presence of flammable liquids, gases or dust.** Power tools create sparks which may ignite the dust or fumes.
- ▶ **Keep children and bystanders away while operating a power tool.** Distractions can cause you to lose control.

#### Electrical safety

- ▶ **Do not expose power tools to rain or wet conditions.** Water entering a power tool will increase the risk of electric shock.

#### Personal safety

- ▶ **Stay alert, watch what you are doing and use common sense when operating a power tool. Do not use a power tool while you are tired or under the influence of drugs, alcohol or medication.** A moment of inattention while operating power tools may result in serious personal injury.
- ▶ **Use personal protective equipment. Always wear eye protection.** Protective equipment such as a dust mask, non-skid safety shoes, hard hat or hearing protection used for appropriate conditions will reduce personal injuries.
- ▶ **Prevent unintentional starting. Ensure the switch is in the off-position before connecting to power source and/or battery pack, picking up or carrying the tool.** Carrying power tools with your finger on the switch or engaging power tools that have the switch on invites accidents.
- ▶ **Remove any adjusting key or wrench before turning the power tool on.** A wrench or a key left attached to a rotating part of the power tool may result in personal injury.
- ▶ **Do not overreach. Keep proper footing and balance at all times.** This enables better control of the power tool in unexpected situations.

- ▶ **Dress properly. Do not wear loose clothing or jewellery. Keep your hair and clothing away from moving parts.** Loose clothes, jewellery or long hair can be caught in moving parts.
- ▶ **If devices are provided for the connection of dust extraction and collection facilities, ensure these are connected and properly used.** Use of dust collection can reduce dust-related hazards.
- ▶ **Do not let familiarity gained from frequent use of tools allow you to become complacent and ignore tool safety principles.** A careless action can cause severe injury within a fraction of a second.

#### Power tool use and care

- ▶ **Do not force the power tool. Use the correct power tool for your application.** The correct power tool will do the job better and safer at the rate for which it was designed.
- ▶ **Do not use the power tool if the switch does not turn it on and off.** Any power tool that cannot be controlled with the switch is dangerous and must be repaired.
- ▶ **Disconnect the plug from the power source and/or remove the battery pack, if detachable, from the power tool before making any adjustments, changing accessories, or storing power tools.** Such preventive safety measures reduce the risk of starting the power tool accidentally.
- ▶ **Store idle power tools out of the reach of children and do not allow persons unfamiliar with the power tool or these instructions to operate the power tool.** Power tools are dangerous in the hands of untrained users.
- ▶ **Maintain power tools and accessories. Check for misalignment or binding of moving parts, breakage of parts and any other condition that may affect the power tool's operation. If damaged, have the power tool repaired before use.** Many accidents are caused by poorly maintained power tools.
- ▶ **Keep cutting tools sharp and clean.** Properly maintained cutting tools with sharp cutting edges are less likely to bind and are easier to control.
- ▶ **Use the power tool, accessories and tool bits etc. in accordance with these instructions, taking into account the working conditions and the work to be performed.** Use of the power tool for operations different from those intended could result in a hazardous situation.
- ▶ **Keep handles and grasping surfaces dry, clean and free from oil and grease.** Slippery handles and grasping surfaces do not allow for safe handling and control of the tool in unexpected situations.

#### Battery tool use and care

- ▶ **Recharge only with the charger specified by the manufacturer.** A charger that is suitable for one type of battery pack may create a risk of fire when used with another battery pack.

- ▶ **Use power tools only with specifically designated battery packs.** Use of any other battery packs may create a risk of injury and fire.
- ▶ **When battery pack is not in use, keep it away from other metal objects, like paper clips, coins, keys, nails, screws or other small metal objects, that can make a connection from one terminal to another.** Shorting the battery terminals together may cause burns or a fire.
- ▶ **Under abusive conditions, liquid may be ejected from the battery; avoid contact. If contact accidentally occurs, flush with water. If liquid contacts eyes, additionally seek medical help.** Liquid ejected from the battery may cause irritation or burns.
- ▶ **Do not use a battery pack or tool that is damaged or modified.** Damaged or modified batteries may exhibit unpredictable behaviour resulting in fire, explosion or risk of injury.
- ▶ **Do not expose a battery pack or tool to fire or excessive temperature.** Exposure to fire or temperature above 130°C may cause explosion.
- ▶ **Follow all charging instructions and do not charge the battery pack or tool outside the temperature range specified in the instructions.** Charging improperly or at temperatures outside the specified range may damage the battery and increase the risk of fire.

#### Service

- ▶ **Have your power tool serviced by a qualified repair person using only identical replacement parts.** This will ensure that the safety of the power tool is maintained.
- ▶ **Never service damaged battery packs.** Service of battery packs should only be performed by the manufacturer or authorized service providers.

## Hammer Safety Warnings

#### Safety instructions for all operations

- ▶ **Wear ear protectors.** Exposure to noise can cause hearing loss.
- ▶ **Use auxiliary handle(s), if supplied with the tool.** Loss of control can cause personal injury.
- ▶ **Hold the power tool by insulated gripping surfaces, when performing an operation where the cutting accessory or fasteners may contact hidden wiring.** Cutting accessory or fasteners contacting a "live" wire may make exposed metal parts of the power tool "live" and could give the operator an electric shock.

#### Safety instructions when using long drill bits with rotary hammers

- ▶ **Always start drilling at low speed and with the bit tip in contact with the workpiece.** At higher speeds, the bit is likely to bend if allowed to rotate freely without contacting the workpiece, resulting in personal injury.
- ▶ **Apply pressure only in direct line with the bit and do not apply excessive pressure.** Bits can bend, causing breakage or loss of control, resulting in personal injury.

#### Additional safety information

- ▶ **Use suitable detectors to determine if there are hidden supply lines or contact the local utility company for assistance.** Contact with electric cables can cause fire and electric shock. Damaging gas lines can lead to explosion. Breaking water pipes causes property damage.
- ▶ **Always wait until the power tool has come to a complete stop before placing it down.** The application tool can jam and cause you to lose control of the power tool.
- ▶ **Secure the workpiece.** A workpiece clamped with clamping devices or in a vice is held more secure than by hand.
- ▶ **In case of damage and improper use of the battery, vapours may be emitted. The battery can set alight or explode.** Ensure the area is well ventilated and seek medical attention should you experience any adverse effects. The vapours may irritate the respiratory system.
- ▶ **Do not modify or open the battery.** There is a risk of short-circuiting.
- ▶ **The battery can be damaged by pointed objects such as nails or screwdrivers or by force applied externally.** An internal short circuit may occur, causing the battery to burn, smoke, explode or overheat.
- ▶ **Only use the battery in the manufacturer's products.** This is the only way in which you can protect the battery against dangerous overload.



**Protect the rechargeable battery against heat, e.g. including prolonged sun exposure, fire, water, and moisture.** There is a risk of explosion and short circuit.

- ▶ **Do not touch any application tools or adjacent housing components shortly after operation.** These can become very hot during operation and cause burns.
- ▶ **The application tool may jam during drilling. Make sure you have a stable footing and hold the power tool firmly with both hands.** Otherwise you could lose control of the power tool.
- ▶ **Take care when carrying out demolition work using the chisel.** Falling fragments of the demolition material could injure you or any bystanders.
- ▶ **Hold the power tool firmly with both hands and make sure you have a stable footing.** The power tool can be more securely guided with both hands.
- ▶ **The mounting for the suspension strap (6) and the suspension strap itself do not act as fall protection.** Use the mounting for the suspension strap (6) only to attach a suspension strap.
- ▶ **Never attach the fall protection system (24) to the mounting for the suspension strap (6).**

## Product Description and Specifications



### Read all the safety and general instructions.

Failure to observe the safety and general instructions may result in electric shock, fire and/or serious injury.

Please observe the illustrations at the beginning of this operating manual.

### Intended Use

The power tool is intended for hammer drilling in concrete, brick and stone, as well as for light chiselling work. It is also suitable for drilling without impact in wood, metal, ceramic and plastic. Power tools with electronic control and right/left rotation are also suitable for screwdriving.

### Product Features

The numbering of the product features refers to the diagram of the power tool on the graphics page.

- (1) SDS plus drill chuck
- (2) SDS plus tool holder
- (3) Dust protection cap
- (4) Locking sleeve
- (5) Vibration damping
- (6) Mounting for suspension strap
- (7) Battery release button<sup>a)</sup>
- (8) Rotational direction switch
- (9) Handle (insulated gripping surface)
- (10) On/off switch
- (11) Rechargeable battery<sup>a)</sup>
- (12) Release button for impact/mode selector switch
- (13) Impact/mode selector switch
- (14) Worklight
- (15) Button for depth stop adjustment
- (16) Auxiliary handle (insulated gripping surface)
- (17) Depth stop
- (18) Securing screw for keyed chuck<sup>a)</sup>
- (19) Keyed chuck<sup>a)</sup>
- (20) SDS plus shank for drill chuck
- (21) Chuck key
- (22) Universal holder with SDS plus shank<sup>b)</sup>
- (23) Attachment area for the fall protection system on the power tool
- (24) Fall protection system<sup>b)</sup>
- (25) Fall protection system anchorage point fixer<sup>b)</sup>

a) **This accessory is not part of the standard scope of delivery.**

b) **This accessory described here is not included with the product as standard, nor is it part of the Bosch range of accessories.**

## Technical Data

Cordless Rotary Hammer		GBH 18V-22
Article number		<b>3 611 J24 0..</b>
Rated voltage	V=	18
Rated speed <sup>A)</sup>		
– Clockwise	min <sup>-1</sup>	0–1050
– Anticlockwise	min <sup>-1</sup>	0–1050
Impact rate at rated speed <sup>A)</sup>	min <sup>-1</sup>	0–4675
Tool holder		SDS plus
Spindle collar diameter	mm	50
Max. drilling diameter		
– Concrete	mm	22
– Steel	mm	13
– Wood	mm	20
Weight <sup>B)</sup>	kg	2.3
Length	mm	308
Height	mm	207
Recommended ambient temperature during charging	°C	0 to +35
Permitted ambient temperature during operation <sup>C)</sup> and during storage	°C	–20 to +50
Compatible rechargeable batteries		GBA18V... GBA 18V... ProCORE18V... EXPERT18V... EXBA18V... CORE18V...
Recommended battery chargers		GAL 18... GAL 18... GAL 36... GAL12V/18... GAL 12V/18... GAX 18... EXAL18...

A) Measured at 20–25 °C with rechargeable battery **GBA 18V 4.0Ah**

B) With auxiliary handle (16), without rechargeable battery (you can find the battery weight at [www.bosch-professional.com](http://www.bosch-professional.com).)

C) Limited performance at temperatures < 0 °C

Values can vary depending on the product, scope of application and environmental conditions. To find out more, visit [www.bosch-professional.com/wac](http://www.bosch-professional.com/wac).

## Noise/Vibration Information

Noise emission values determined according to **EN IEC 62841-2-6**.

### GBH 18V-22:

Typically, the A-weighted noise level of the power tool is: Sound pressure level **93** dB(A); sound power level **101** dB(A). Uncertainty K = **3** dB.

**Wear hearing protection!**

**GBH 18V-22 + GDE 18V-12:**

Typically, the A-weighted noise level of the power tool is: Sound pressure level **94** dB(A); sound power level **102** dB(A). Uncertainty K = **3** dB.

**Wear hearing protection!**

Vibration values  $a_{h_i}$  (continuous vibrations),  $p_F$  (repeated shock vibrations) and uncertainty K determined according to **EN IEC 62841-2-6:**

**GBH 18V-22:**

Hammer drilling in concrete:  $a_{h,HD} = 18.1$  m/s<sup>2</sup> (K = **1.5** m/s<sup>2</sup>),  $p_{F,HD} = 897$  m/s<sup>2</sup> (K = **175** m/s<sup>2</sup>)

Chiselling:  $a_{h,ChEq} = 12.8$  m/s<sup>2</sup> (K = **1.5** m/s<sup>2</sup>),

$p_{F,ChEq} = 588$  m/s<sup>2</sup> (K = **82** m/s<sup>2</sup>)

**GBH 18V-22 + GDE 18V-12:**

Hammer drilling in concrete:  $a_{h,HD} = 16.1$  m/s<sup>2</sup> (K = **1.5** m/s<sup>2</sup>),  $p_{F,HD} = 874$  m/s<sup>2</sup> (K = **34** m/s<sup>2</sup>)

The vibration level and noise emission value given in these instructions have been measured in accordance with a standardised measuring procedure and may be used to compare power tools. They may also be used for a preliminary estimation of vibration and noise emissions.

The stated vibration level and noise emission value represent the main applications of the power tool. However, if the power tool is used for other applications, with different accessories or is poorly maintained, the vibration level and noise emission value may differ. This may significantly increase the vibration and noise emissions over the total working period.

To estimate vibration and noise emissions accurately, the times when the tool is switched off or when it is running but not actually being used should also be taken into account. This may significantly reduce vibration and noise emissions over the total working period.

Implement additional safety measures to protect the operator from the effects of vibration, such as servicing the power tool and accessories, keeping their hands warm, and organising workflows correctly.

**Dust emission information****with GDE 18V-12**

Dust emission values determined according to **EN 50632-2-6:**

Respirable dust: < **0.5** mg/m<sup>3</sup>, K = **0** mg/m<sup>3</sup>

Inhalable dust: < **0.45** mg/m<sup>3</sup>, K = **0.2** mg/m<sup>3</sup>

Quarz dust: < **0.05** mg/m<sup>3</sup>

The indicated dust emission value was determined under the following operating conditions:

Operating mode: Hammer drilling

Application tool: SDS plus drill bit, diameter **10** mm

**Note:** If the power tool is used in another operating mode, with other application tools or is poorly maintained, the dust emission value may differ. This may significantly increase dust emissions over the total working period.

If necessary, establish additional safety measures to protect the operator from the effects of dust emissions, for example:

Wear a P2 filter class breathing mask.

The regulations on the material being machined that apply in the country of use must be observed.

**Rechargeable battery**

**Bosch** sells some cordless power tools without a rechargeable battery. You can tell whether a rechargeable battery is included with the power tool by looking at the packaging.

**Charging the battery**

► **Use only the chargers listed in the technical data.** Only these chargers are matched to the lithium-ion battery of your power tool.

**Note:** Lithium-ion rechargeable batteries are supplied partially charged according to international transport regulations. To ensure full rechargeable battery capacity, fully charge the rechargeable battery before using your tool for the first time.

**Inserting the Battery**

Push the charged battery into the battery holder until it clicks into place.

**Removing the Battery**



To remove the rechargeable battery, press the battery release button and pull the battery out. **Do not use force to do this.**

The rechargeable battery has two locking levels to prevent the battery from falling out if the battery release button is pressed unintentionally. The rechargeable battery is held in place by a spring when fitted in the power tool.

**Battery charge indicator**

**Note:** Not all battery types have a battery charge indicator.

The green LEDs on the battery charge indicator indicate the state of charge of the battery. For safety reasons, it is only possible to check the state of charge when the power tool is not in operation.

Press the button for the battery charge indicator  or  to show the state of charge. This is also possible when the battery is removed.

If no LED lights up after pressing the button for the battery charge indicator, then the battery is defective and must be replaced.

**Rechargeable battery type GBA 18V... | GBA18V...**

LED	Capacity
3× continuous green light	60–100 %
2× continuous green light	30–60 %
1× continuous green light	5–30 %
1× flashing green light	0–5 %

## Battery model ProCORE18V... | EXPERT18V... | EXBA18V... | CORE18V...





LED	Capacity
5 × continuous green light	80–100 %
4 × continuous green light	60–80 %
3 × continuous green light	40–60 %
2 × continuous green light	20–40 %
1 × continuous green light	5–20 %
1 × flashing green light	0–5 %

### Battery defect risk detection

#### EXPERT18V... | EXBA18V...

In addition to the state of charge of the rechargeable battery, the LEDs on the battery charge indicator can also indicate the risk of a battery defect.

To activate the function, press and hold the button for the battery charge indicator  for 3 seconds. The analysis of the battery is signalled by a moving light on the battery charge indicator. The result of is shown on the battery charge indicator.

 **1 LED:** The rechargeable battery has a high defect risk. Performance and runtime may already be reduced. Replacing the rechargeable battery is recommended.

 **5 LEDs:** The rechargeable battery is in good condition and has a low defect risk.

**Please note:** The rechargeable battery defect risk assessment works in a binary manner and offers a simplified status assessment, indicating either that the rechargeable battery is in good condition or that the rechargeable battery has an increased defect risk. A percentage of the battery status is not shown.

### Recommendations for Optimal Handling of the Battery

Protect the battery against moisture and water.

Only store the battery within a temperature range of –20 to 50 °C. Do not leave the battery in your car in the summer, for example.

Occasionally clean the ventilation slots on the battery using a soft brush that is clean and dry.

A significantly reduced operating time after charging indicates that the battery has deteriorated and must be replaced. Follow the instructions on correct disposal.

## Assembly

- ▶ **Before carrying out any work on the power tool (e.g. maintenance, tool change etc.), remove the battery from the power tool.** There is risk of injury from unintentionally pressing the on/off switch.

## Auxiliary handle

- ▶ **Do not operate your power tool without the auxiliary handle (16).**
- ▶ **Make sure that the auxiliary handle is always tightened.** Otherwise you could lose control of the power tool when working.

### Swivelling the auxiliary handle (see figure A)

You can swivel the auxiliary handle (16) to any angle for a safe work posture that minimises fatigue.

- Turn the lower gripping end of the auxiliary handle (16) anticlockwise and swivel the auxiliary handle (16) into the required position. Then turn the lower gripping end of the auxiliary handle (16) clockwise to retighten it. Make sure that the retaining strap of the auxiliary handle slots into the corresponding groove of the housing.

### Selecting drill chucks and tools

For hammer drilling and chiselling, you will need SDS plus tools, which insert into the SDS plus drill chuck.

For drilling without impact in wood, metal, ceramic and plastic as well as for screwdriving, tools without SDS plus are used (e.g. cylindrical shank drill bits). A keyed chuck is required for such drilling tools.

**Note:** Only use the keyed chuck in the **drilling without impact** operating mode.

### Changing the drill chuck

#### Inserting/removing the keyed chuck

You must use a suitable drill chuck (keyed or keyless chuck) to work with tools that do not have SDS plus (e.g. cylindrical shank drill bits).

#### Fitting the keyed chuck (see figure B)

- Screw the SDS plus shank (20) into a keyed chuck (19). Secure the keyed chuck (19) using the securing screw (18). **Note that the securing screw has a left-hand thread.**

#### Inserting the keyed chuck (see figure B)

- Clean and lightly grease the insertion end of the shank.
- Insert the keyed chuck with the adapter shank into the tool holder with a turning motion until it automatically locks.
- Check that it is locked by pulling the keyed chuck.

#### Removing the keyed chuck

- Push the locking sleeve (4) back and remove the keyed chuck (19).

### Changing the tool

The dust protection cap (3) largely prevents the penetration of drilling dust into the tool holder during operation. When inserting the tool, make sure that the dust protection cap (3) does not become damaged.

- ▶ **Replace a damaged dust protection cap immediately. It is recommended that you have use an after-sales service for this.**

## Changing the tool SDS plus

### Inserting the SDS plus Application Tool (see figure C)

The SDS plus drill chuck (1) enables you to change the application tool easily and conveniently without needing to use additional tools.

- Clean and lightly grease the shank of the application tool.
- Insert the application tool into the tool holder (2) while turning it until it locks automatically.
- Check that it is locked by pulling on the tool.

As a requirement of the system, the SDS plus application tool can move freely. This causes a certain radial run-out at no-load, which has no effect on the accuracy of the drill hole, as the drill bit centres itself upon drilling.

### Removing the SDS plus Application Tool (see figure D)

- Push the locking sleeve (4) back and remove the application tool.

## Changing the keyed chuck

### Inserting the application tool (see figure E)

**Note:** Application tools that do not have SDS plus must not be used for hammer drilling or chiselling. Tools without SDS plus and their drill chucks are damaged by hammer drilling or chiselling.

- Insert a keyed chuck (19).
- Open the keyed chuck (19) by turning it until the tool can be inserted. Insert the tool.
- Insert the chuck key (21) into the corresponding holes of the keyed chuck (19) and clamp the tool evenly.
- Turn the impact/mode selector switch (13) to the "drilling" position.

### Removing the application tool (see figure F)

- Use the chuck key (21) to turn the sleeve of the keyed chuck (19) anticlockwise until the application tool can be removed.

## Dust Reduction

Do not perform work without taking dust-reducing measures. Depending on the intended application, the power tool can be combined with a dust-reducing accessory together with a dust extractor.

Always use suitable breathing protection. The regulations on the materials being machined that apply in the country of use must be observed.

- ▶ **Avoid dust accumulation at the workplace.** Dust can easily ignite.

### Requirements for the Dust Extractor

Recommended hose nominal diameter	mm	<b>35</b>
Required vacuum pressure <sup>A)</sup>	mbar	≥ <b>230</b>
	hPa	≥ <b>230</b>
Required flow rate <sup>A)</sup>	l/s	≥ <b>36</b>
	m <sup>3</sup> /h	≥ <b>129.6</b>
Recommended filter efficiency	Dust class M <sup>B)</sup>	

A) Power value at the power tool's dust extractor connection

B) According to IEC/EN 60335-2-69

Refer to the dust extractor's instructions. If there is reduced suction power, stop working and eliminate the cause.

## Dust extraction with GDE 18V-12/GDE 12 (see figure G)

The GDE 18V-12/GDE 12 dust extraction attachment (accessory) is required for extracting concrete dust and stone dust.

This dust extraction system is not suitable for dust from wood, metal and plastic or for dust which is harmful to one's health (e.g. asbestos).

## Operation

### Start-up

#### Setting the operating mode

The operating mode of the power tool is selected using the impact/mode selector switch (13).

- To change the operating mode, press the release button (12) and turn the impact/mode selector switch (13) until it clicks into the required position.

**Note:** Only change the operating mode when the power tool is switched off. Otherwise, the power tool may become damaged.

 Position for **hammer drilling** into concrete or stone

 Position for **drilling** without impact in wood, metal, ceramic and plastic and for **screwdriving**

 **Vario-Lock** position for adjusting the chisel position  
The impact/mode selector switch (13) will not engage in this position.

 Position for **chiselling**

#### Setting the rotational direction

The rotational direction switch (8) is used to change the rotational direction of the power tool. However, this is not possible while the on/off switch (10) is being pressed.

- ▶ **Only operate the rotational direction switch (8) when the power tool is not in use.**

Always set the rotational direction to clockwise rotation for hammer drilling, drilling and chiselling.

 **Clockwise:** To drill and to drive in screws, press the rotational direction switch (8) through to the left stop.

 **Anticlockwise:** To loosen and unscrew screws and nuts, press the rotational direction switch (8) through to the right stop.

**Note:** If the rotational direction switch is in the middle position, the on/off switch is blocked.

### Switching On/Off

- To **switch on** the power tool, press the on/off switch (10).

The worklight (14) lights up when the on/off switch (10) is lightly or fully pressed, allowing the work area to be illuminated in poor lighting conditions.

When switching on the power tool for the first time, the start may be slightly delayed as the power tool's electronic system has to configure itself first.

For low temperatures, the power tool reaches the full hammer/impact capacity only after a certain time.

- To **switch off** the power tool, release the on/off switch (10).

### Adjusting the speed/impact rate

You can adjust the speed/impact rate of the power tool when it is on by pressing in the on/off switch (10) to varying extents.

Applying light pressure to the on/off switch (10) results in a low rotational speed/impact rate. Applying increasing pressure to the switch increases the speed/impact rate.

### Changing the chiselling position (Vario-Lock)

You can lock the chisel in 36 different positions, so you can select the optimum working position for each task.

- Insert the chisel into the tool holder.
- Turn the impact/mode selector switch (13) to the "Vario-Lock" position.
- Turn the application tool to the required chisel position.
- Turn the impact/mode selector switch (13) to the "chiselling" position. With this, the tool holder is locked.
- Set the rotational direction for chiselling to clockwise.

## Practical advice

### Setting the drilling depth (see figure H)

You can use the depth stop (17) to set the required drilling depth X.

- Press the button for depth stop adjustment (15) and insert the depth stop into the auxiliary handle (16). The fluting on the depth stop (17) must face downwards.
- Push the SDS plus application tool into the SDS plus tool holder (2) as far as it will go. Otherwise, the movability of the SDS plus drilling tool can lead to incorrect adjustment of the drilling depth.
- Pull the depth stop far enough out that the distance between the drill bit tip and the edge of the depth stop corresponds to the required drilling depth X.

### Overload clutch

- ▶ **If the application tool jams or snags, the power transmission to the drill spindle will be interrupted. Always hold the power tool firmly with both hands to withstand the forces this may create and adopt a position with stable footing.**

- ▶ **Switch the power tool off immediately and remove the application tool if the power tool becomes blocked. Switching on when the application tool is blocked may cause high torque reactions.**

### Rapid shut-off (KickBack Control)



The rapid shut-off function (KickBack Control) gives the user greater control over the power tool and offers them better protection than power tools that do not have KickBack Control.

The power tool will switch off if it suddenly and unforeseeably rotates around the drilling axis.

- To **switch the tool back on**, release the on/off switch (10) and then press it again.

Rapid shut-off is indicated by flashing of the worklight (14) on the power tool.

### Vibration damping



The integrated vibration damping function reduces the generated vibration.

- ▶ **Do not continue to use the power tool if the damping element is damaged.**

### Inserting screwdriver bits (see figure I)

- ▶ **Only apply the power tool to the screw/nut when the tool is switched off.** Rotating tool inserts can slip off.

A universal holder (22) with SDS plus shank is required to work with screwdriver bits.

- Clean and lightly grease the insertion end of the shank.
- Insert the universal holder into the tool holder while turning it until it locks automatically.
- Check that it is locked by pulling the universal holder.
- Insert a screwdriver bit in the universal holder. Only use screwdriver bits that fit the screw head.
- To remove the universal holder, slide the locking sleeve (4) backwards and remove the universal holder (22) from the tool holder.

### Attaching the Fall Protection System (see figure J)

**Note:** A fall protection system (24) that is suitable for the weight of the entire system should be used to prevent the power tool from falling. Please always refer to the permitted attachment area (23) on the power tool.

It is best to use the fall protection system with a tape loop secured by an anchor knot or a fall protection system with fall damper.

Please always refer to the operating instructions when attaching the fall protection system (24).

- ▶ **Always secure the opposite side of the fall protection system to a stable structure (e.g. a building or scaffolding) and never to the user.**

The fall protection system must be able to move freely and may only be attached to the power tool at the fixed anchorage point (25) and in the permitted attachment area (23).

Select the fixed anchorage point (25) such that the power tool can fall freely into the fall protection sys-

**tem without wrapping around or putting the user at risk of harm in the event of a fall.**

**Never use the fall protection system on a power tool which has been fitted with the GDE 18V-12 dust extraction attachment.**

## Maintenance and Service

### Maintenance and cleaning

- ▶ **Before carrying out any work on the power tool (e.g. maintenance, tool change etc.), remove the battery from the power tool.** There is risk of injury from unintentionally pressing the on/off switch.
- ▶ **To ensure safe and efficient operation, always keep the power tool and the ventilation slots clean.**
- ▶ **Replace a damaged dust protection cap immediately. It is recommended that you have use an after-sales service for this.**
  - Clean the tool holder (2) after each use.

### After-Sales Service and Application Service

#### Great Britain

Tel. Service: (0344) 7360109

#### GB Importer:

Robert Bosch Ltd.  
Broadwater Park  
North Orbital Road  
Uxbridge  
UB9 5HJ

In all correspondence and spare parts orders, please always include the 10-digit article number given on the nameplate of the product.

### Disposal

Power tools, rechargeable batteries, accessories and packaging should be sorted for environmental-friendly recycling.



Do not dispose of power tools and batteries/rechargeable batteries into household waste!

#### Only for EU countries and United Kingdom:

Electrical and electronic equipment or used batteries that are no longer suitable for use must be collected separately and disposed of in an environmentally friendly manner. Use the designated collection systems. Incorrect disposal may cause harmful effects on the environment and human health, due to the potential presence of hazardous substances.

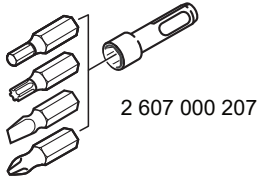

2 607 000 207



2 608 002 021

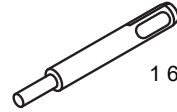

1 618 600 007

1 613 001 010

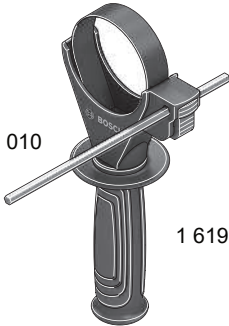

1 619 P16 971

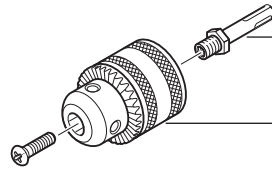

1 617 000 132  
SDS plus

1 608 571 062  
1,5 - 13 mm



1 607 950 045

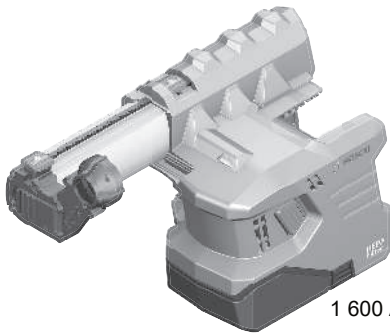

1 600 A02 8H6

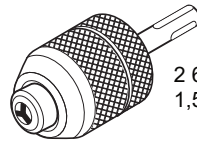

2 608 572 227  
1,5 - 13 mm

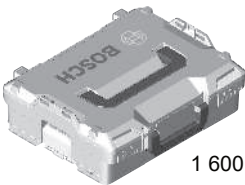

1 600 A01 2G0

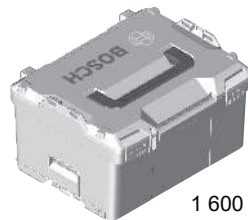

1 600 A01 2G2

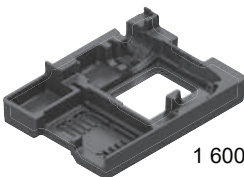

1 600 A02 NS7

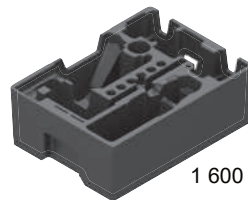

1 600 A02 NS8

# Legal Information and Licenses

## Copyright (c) 2015, Infineon Technologies AG

All rights reserved.

Redistribution and use in source and binary forms, with or without modification, are permitted provided that the following conditions are met:

- Redistributions of source code must retain the above copyright notice, this list of conditions and the following disclaimer.
- Redistributions in binary form must reproduce the above copyright notice, this list of conditions and the following disclaimer in the documentation and/or other materials provided with the distribution.
- Neither the name of the copyright holders nor the names of its contributors may be used to endorse or promote products derived from this software without specific prior written permission.

THIS SOFTWARE IS PROVIDED BY THE COPYRIGHT HOLDERS AND CONTRIBUTORS "AS IS" AND ANY EXPRESS OR IMPLIED WARRANTIES, INCLUDING, BUT NOT LIMITED TO, THE IMPLIED WARRANTIES OF MERCHANTABILITY AND FITNESS FOR A PARTICULAR PURPOSE ARE DISCLAIMED. IN NO EVENT SHALL THE COPYRIGHT HOLDER OR CONTRIBUTORS BE LIABLE FOR ANY DIRECT, INDIRECT, INCIDENTAL, SPECIAL, EXEMPLARY, OR CONSEQUENTIAL DAMAGES (INCLUDING, BUT NOT LIMITED TO, PROCUREMENT OF SUBSTITUTE GOODS OR SERVICES; LOSS OF USE, DATA, OR PROFITS; OR BUSINESS INTERRUPTION) HOWEVER CAUSED AND ON ANY THEORY OF LIABILITY, WHETHER IN CONTRACT, STRICT LIABILITY, OR TORT (INCLUDING NEGLIGENCE OR OTHERWISE) ARISING IN ANY WAY OUT OF THE USE OF THIS SOFTWARE, EVEN IF ADVISED OF THE POSSIBILITY OF SUCH DAMAGE.

## Warranty Disclaimer

This product contains Open Source Software components which underly Open Source Software Licenses. Please note that Open Source Licenses contain disclaimer clauses. The text of the Open Source Licenses that apply are included in this manual under "Legal Information and Licenses".



Servicekontakte  
Service Contacts  
Contacts de Service  
Contactos de Servicio



<https://www.bosch-pt.com/serviceaddresses>

Garantiebedingungen  
Guarantee Conditions  
Conditions de Garantie  
Condiciones de Garantía



<https://www.bosch-pt.com/guarantee/202601>